



**Catalogue**  
FOOD SERVICE  
**Chapter**  
COOK & CHILL

**Specific model**  
SVP-2-455/25 230V 50/60Hz

19075913

21/07/2022

**DENOMINATION:**

Vacuum packer with 2 horizontal bars of 455 mm and pump capacity of 25m<sup>3</sup>/h.

**DESCRIPTION :**

- Vacuum packers with digital controls, controlled by sensor.
- Made of stainless steel, no sharp corners and rounded edges.
- 2 units of high-quality polycarbonate fill sheets.
- High-precision microprocessor which controls the vacuum percentage of the chamber, therefore enabling precise and consistent results at all times, regardless of the type/quantity of the product to be packaged.
- Digital control panel with display included.
- Easily programmable memory for 10 programmes.
- Possibility of performing additional 60" vacuum.
- Possibility of packaging liquids.
- H2Oout programme to dehumidify the pump.
- Programme for external packing both in bags and containers.
- All models include Busch pumps.
- Reed switch for automatic start the vacuum cycle once the lid is closed.
- Lid with gas shock absorbers for smooth opening.
- Piston with two positions: operation and standby. In standby position, the lid is not stressed by the piston, ensuring that it does not become deformed over time.
- Cable-free sealing bars with pneumatic pistons. Their shape ensures a hermetic seal even when using multiple packaging (2-3 bags).
- Protection against possible entry of water into the machine.
- Thanks to the injection of inert gas, the G models make it possible to package delicate or soft products.
- Oil level indicator.
- Audio and visual alarms: vacuum alarm (warning if the configured vacuum level is not reached) and oil change.
- Visualisation of the complete machine cycles.
- Tilting opening system which enable easy access to all parts for maintenance.
- Internal electronic cards, protected with hermetic casing (waterproof and flame retardant).
- Easy to replace teflon of the sealing bar."

**POSSIBLE ACCESSORIES :**

- ACCESSORIES
- LIQUID PACKAGING
- EMPTY INTO CONTAINERS

**DIMENSIONS**

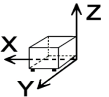

X Width	607 mm	X Gross width	880 mm
Y Depth	692 mm	Y Gross depth	750 mm
Z Height	1002 mm	Z Gross height	1350 mm
Net Weight	116,0 kg	Gross Weight	154,0 kg
Net volume	0,420 m <sup>3</sup>	Gross volume	0,891 m <sup>3</sup>

**ELECTRICITY TECHNICAL SPECIFICATIONS**

Electric power	1,200 kW
Voltage	220-240V - 1N
Electric frequency	50/60Hz



**Catalogue**  
FOOD SERVICE  
**Chapter**  
COOK & CHILL

**Specific model**  
SVP-2-455/25 230V 50/60Hz

19075913

21/07/2022

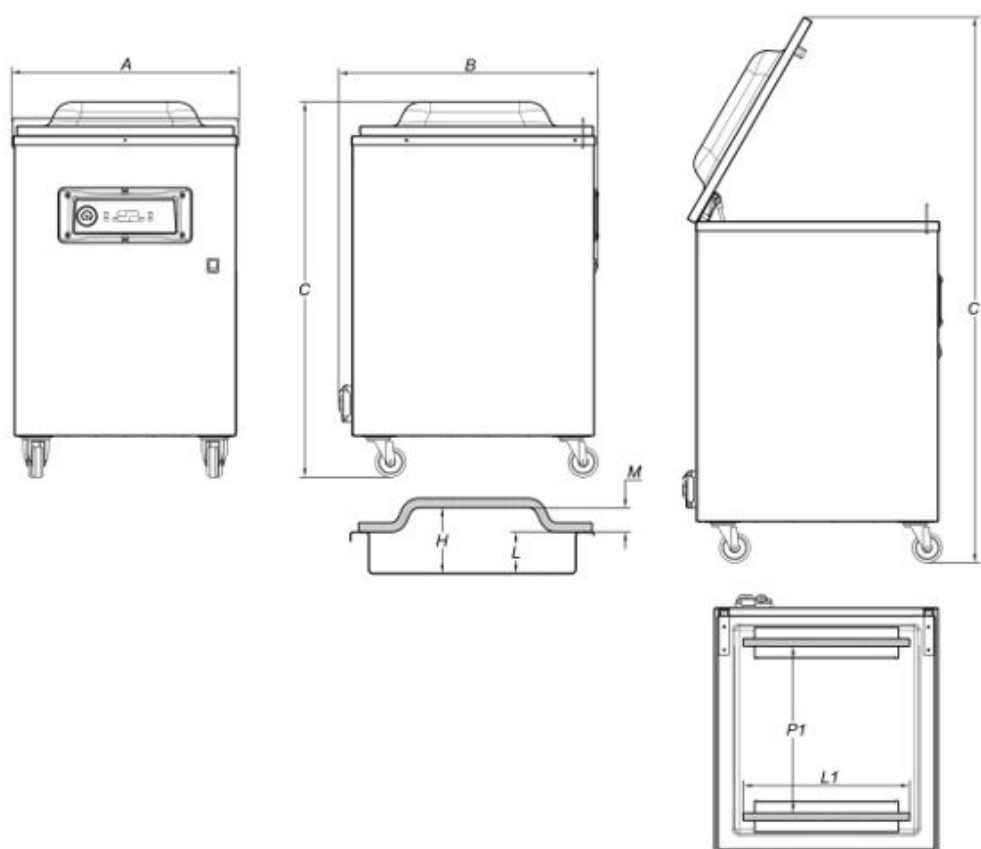

## SPECIFICATIONS

N. bars / N. barras	Nº	2
Length of seal L1 / Longitud de barra L1	mm	455
Chamber Size (FxGxH) / Tamaño cámara (FxGxH)	mm	556x492x175
Useful space Chamber (P1) / Dimensiones cámara (P1)	mm	446
Chamber depth (L) / Profundidad cámara (L)	mm	110
Chamber volume / Volumen cámara	Lt	37,5
Overall dimensions (AxBxC) / Dimensiones generales (AxBxC)	mm	607x692x1002
Maximum height with open lid (C1) / Altura máx. tapa abierta (C1)	mm	1458
Weight (with shelves) / Peso (con planchas relleno)	kg	115,5
Noise level / Nivel ruido	dB(A)	57
Environmental operating temperature (min-max) / Temperatura ambiental de trabajo (min-max)	°C	12-40